



POS-NR.	BENENNUNG	BESCHREIBUNG	MENGE	ABAS NR.
1	NS271K	Doppelkontaktelement	1	13269
2	19924-LEB-0608-PW	LEB-0608-PW Lasersetikett (NS2)	6	19924

 <b>Spohn-Burkhardt</b> <small>Elektrotechnische Fabrik Blaubeuren</small> <b>Spohn &amp; Burkhardt GmbH &amp; Co. KG</b> Mauergasse 5 · 89143 Blaubeuren/Germany Tel.: +49 7344 171-0 info@spobu.de Fax: +49 7344 171-99 www.spobu.de	<b>Rev</b>				Zeichnung Nr. <b>EPACK51910</b> Beschreibung: <b>Ersatzteilpaket Doppelkontaktelement</b> silber für Joystick VNS2
		Datum	Name		
	Erstellt	09.12.2016	G.Hock		
	Geprüft	18.08.2020	T.Frankenhauser		
	Freigeg.	25.09.2020	A.Mangold		
	Gedruckt	25.09.2020			
				Oberfl.beh.	roh
				Nach.beh.	
				Farbe	
				Farbstruktur	
Allgemeintoleranzen nach DIN ISO 2768 - m Ausdruck kann veraltet sein DIN 6 T1 - Proj.methode 1  Schutzvermerk ISO 16016 beachten	Gewicht 2,74 kg Material Material <nicht festgelegt> Halbzeug	Spobu-ABAS-Nr. <b>51910</b>	DINA4 Maßstab <b>1:1</b> Blatt / von <b>1 / 2</b>		



Ersatzteilpaket Doppelkontaktelement silber für Joystick VNS2  
Spare parts pack Double contact element with silver plated contacts for VNS2

Artikel Nr. / Ident No. : 51910

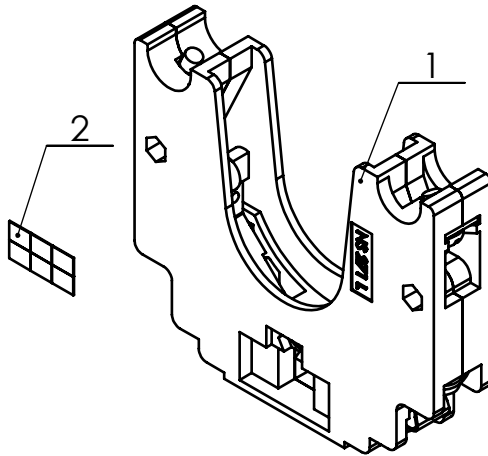

Pos. Nr. Item No.	Typenschlüssel Type code	Bezeichnung	Description	Menge Qty.
1	NS271K	Doppelkontaktelement Silberkontakt für VNS2	Double contact element	1
2	19924-LEB-0608-PW	LEB-0608-PW Laseretikett (NS2)	Laser label	6