



# Spohn + Burkhardt

Elektrotechnische Fabrik Blaubeuren

Griffoberteil für VNS0+VCS0 mit Kappe für G41  
Handle top for VNS0+VCS0 with cap for G41

Artikel Nr.: 47192

Ident No.:

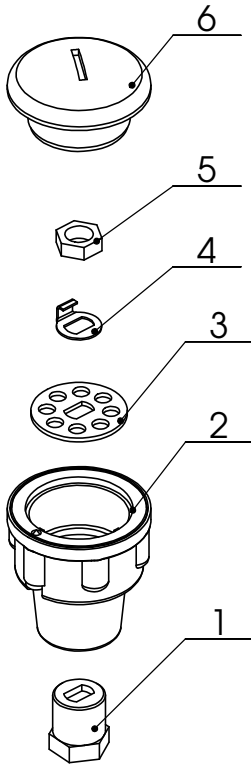

vor Montage/before mounting



nach Montage/after mounting

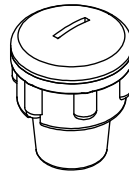

Pos. Nr. Item No.	Typenschlüssel Type code	Bezeichnung Description	Menge Qty.
1	NS0 ES2	Mitnehmerbuchse Locating bush	1
2	NS0 ES41D	Schaltgriff inkl. Schraube Knob base including screw	1
3	NS0 ES3B	Lochscheibe Hole washer	1
4	NS0 ES106	Sicherungsblech Safety washer	1
5	NS034M8X1	Mutter Hexagon nut	1
6	NS0 ES42	Kappe Cap	1

Gewicht: 139.47 g  
 Gesamtkosten (Monat/Jahr):

Allgemeintoleranzen nach ISO 2768 m  
 Fertigung durch: xxxx

A

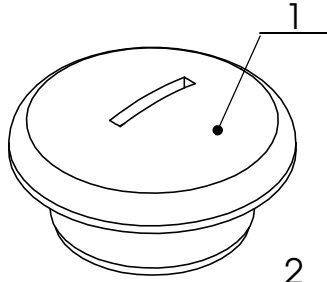

vor Montage/before mounting



B

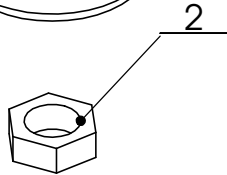

nach Montage/after mounting

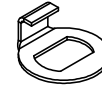

C

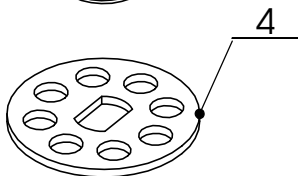
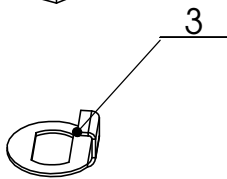

D

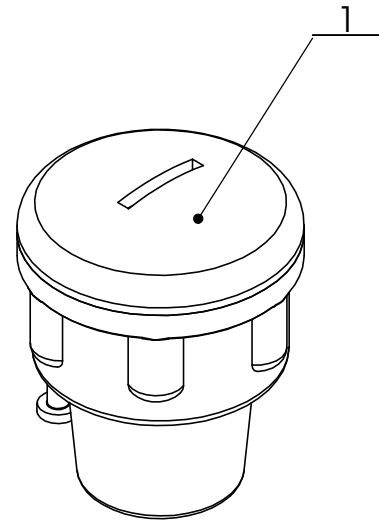
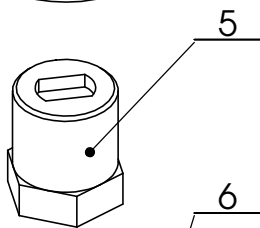

E

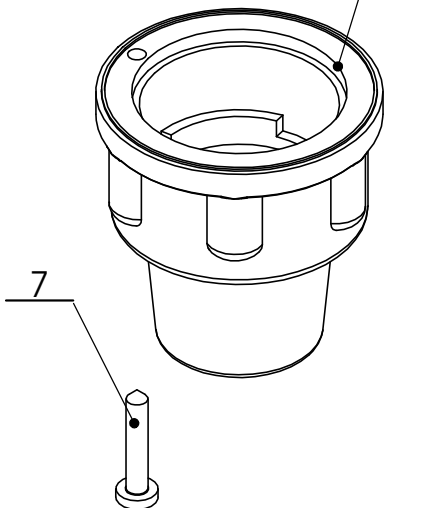

POS-NR.	BENENNUNG	BESCHREIBUNG	MENGE	ABAS NR.
1	NS0 ES42	Kappe	1	12765
2	NS034-M8x1	Mutter SW 11	1	12767
3	NS0 ES106	Sicherungsblech	1	16904
4	NS0 ES3B	Lochscheibe	1	13257
5	NS0 ES2	Mitnehmerbuchse	1	11164
6	NS0 ES41D	Schaltgriff	1	11732
7	ISO 7049 - M2,9 x 16 - C - A2	Linsen-Blechschaube mit Spitze mit Philips-Kreuzschlitz, rostfrei A2	1	17449

POS-NR.	BENENNUNG	BESCHREIBUNG	MENGE	ABAS NR.
1	NS0 ES90	Griffoberteil kpl. ohne Taste	1	13743

F



D-89143 Blaubeuren/Germany Mauergasse 5  
 Fon +49 7344 171-0 info@spobu.de  
 Fax +49 7344 171-99 www.spobu.com

	Datum	Name
Erstellt	24.07.2015	G.Hock
Gedruckt	29.10.2015	
Geprüft		
ABAS Nr.	47192	
Material:	xxxx	
Oberfläche:	xxxx	

Beschreibung:		Zeichnung Nr.	A4
Griffoberteil für NS0 mit Kappe für G41			
		E9-9-1	
Pfad:S:\E-Liste-Päckchen\		Maßstab: 1:1	Blatt 1 von 1